

## 5 Knuckle Swing Clear Hinges

### Standard Weight Plain Bearing "Swing Clear" Full Mortise

Steel – polished and plated or phosphated and prime coated for painting

F248 – (ANSI A8123)



- Equipped with easily seated non-rising pins
- Reversible flush tips and pins
- Ideal for remodeling or new construction
- Available for full mortise application on square edge doors only
- Designed to replace existing 3 1/2" (89mm) or 4" (102mm) hinges for Swing Clear openings (some modification of preparation may be required for residential use)
- Designed to swing doors completely clear of the opening when door is opened 95°

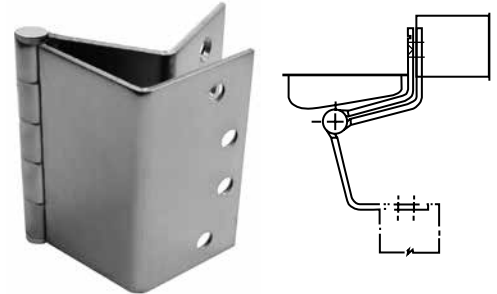

Class Number	Size Length of Joint		Gauge of Metal		Flat Head Screws/ Per Piece	Quantity Per Box	Quantity Per Case	Case Weight	
	Inches	(mm)	Inches	(mm)				Lbs.	(Kg)
F248	3 1/2	(89)	.123	(3.1)	6-10 x 1	2 ea.	20 ea.	16	(7)
	4	(102)	.130	(3.3)	8-12 x 1 1/4	2 ea.	20 ea.	24	(11)

### Standard Weight Concealed Bearing "Swing Clear" Full Mortise

Steel – polished and plated or phosphated and prime coated for painting

CB248 – (ANSI A8122)

CB258 – (ANSI A8122)

Stainless steel – highly polished or satin finish

STSCB248 – (ANSI A5122)

STSCB258 – (ANSI A5122)



- Reversible flush tips and pins
- Ideal for remodeling or new construction
- Specify CB248 and STSCB248 for full mortise application on square edge doors
- Specify CB258 and STSCB258 for full mortise application on bevel edge doors
- Designed to swing doors completely clear of the opening when door is opened 90°
- Concealed bearing is maintenance-free – no oil, no grease
- Hinges can be furnished with hospital tips (HT)
- Limited lifetime warranty

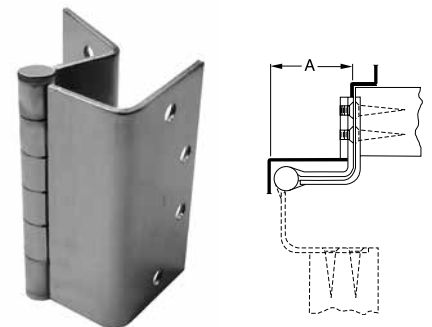

**CB248 (Shown) and STSCB248**  
{For square edge doors}

**CB258 and STSCB258**  
{For doors beveled 1/8" in 2" (3.2 in 51mm)}

Class Number	Size Length of Joint		Minimum Clearance Required Dimensions "A"		Gauge of Metal		Flat Head Screws/ Per Piece		Quantity Per Box	Quantity Per Case	Case Weight	
	Inches	(mm)	Inches	(mm)	Inches	(mm)	Frame Leaf Machine	Door Leaf Wood			Lbs.	(Kg)
CB248, STSCB248	4 1/2	(114)	2 1/8	(54)	.134	(3.4)	4-12-24 x 1/2	4-12 x 1 1/4	3 ea.	24 ea.	36	(17)
CB258, STSCB258	4 1/2	(114)	2 1/8	(54)	.134	(3.4)	4-12-24 x 1/2	4-12 x 1 1/4	3 ea.	24 ea.	36	(17)